

PHYSICAL WIRING DIAGRAM FOR TRIX DIESEL FLYER (20/58)

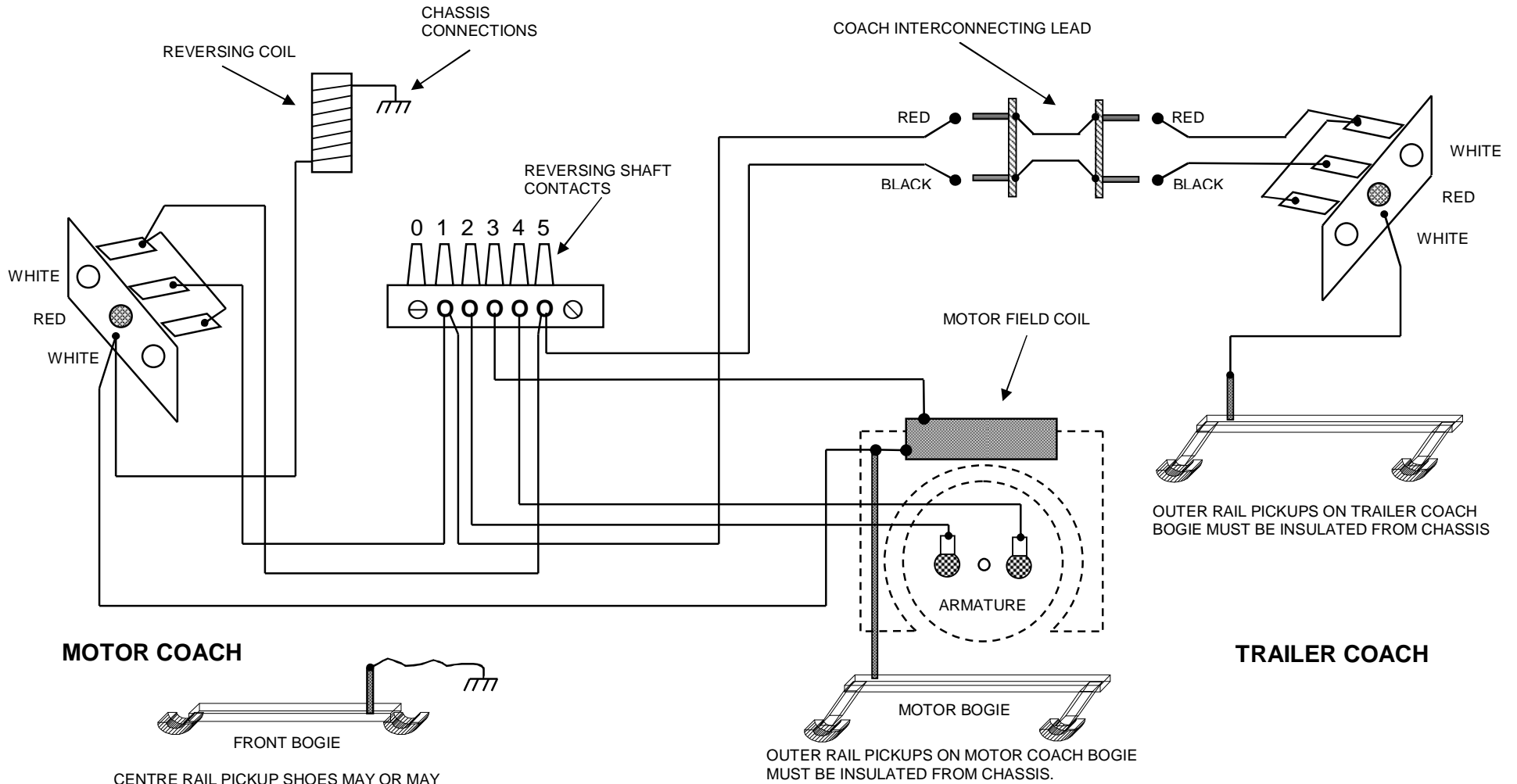

CENTRE RAIL PICKUP SHOES MAY OR MAY NOT BE INSULATED. MUST BE CONNECTED TO CHASSIS OF DMU.

IF RED LAMP AT FRONT END LIGHTS WHEN MOTOR COACH RUNS FORWARDS, CHANGE WIRES 2 AND 4.
 IF RED LAMP ON TRAILER COACH LIGHTS WHEN MOTOR COACH RUNS BACKWARDS, REVERSE ONE OF THE COACH INTERCONNECTION PLUGS.